

Circle.Tech

The new shape of filtration.

The circle represents perfection, the traditional symbol of something that has neither beginning nor end, formed of a single line whose ends join together and cancel each other out. Inspired by this form, Falmecc has developed a new line of hoods that combine extraction and filtration in a single element, allowing maximum efficiency and minimum impact on space.

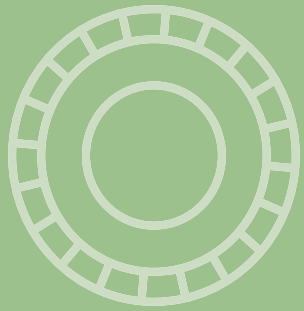

Circle.Tech Technology

Technical sheet.

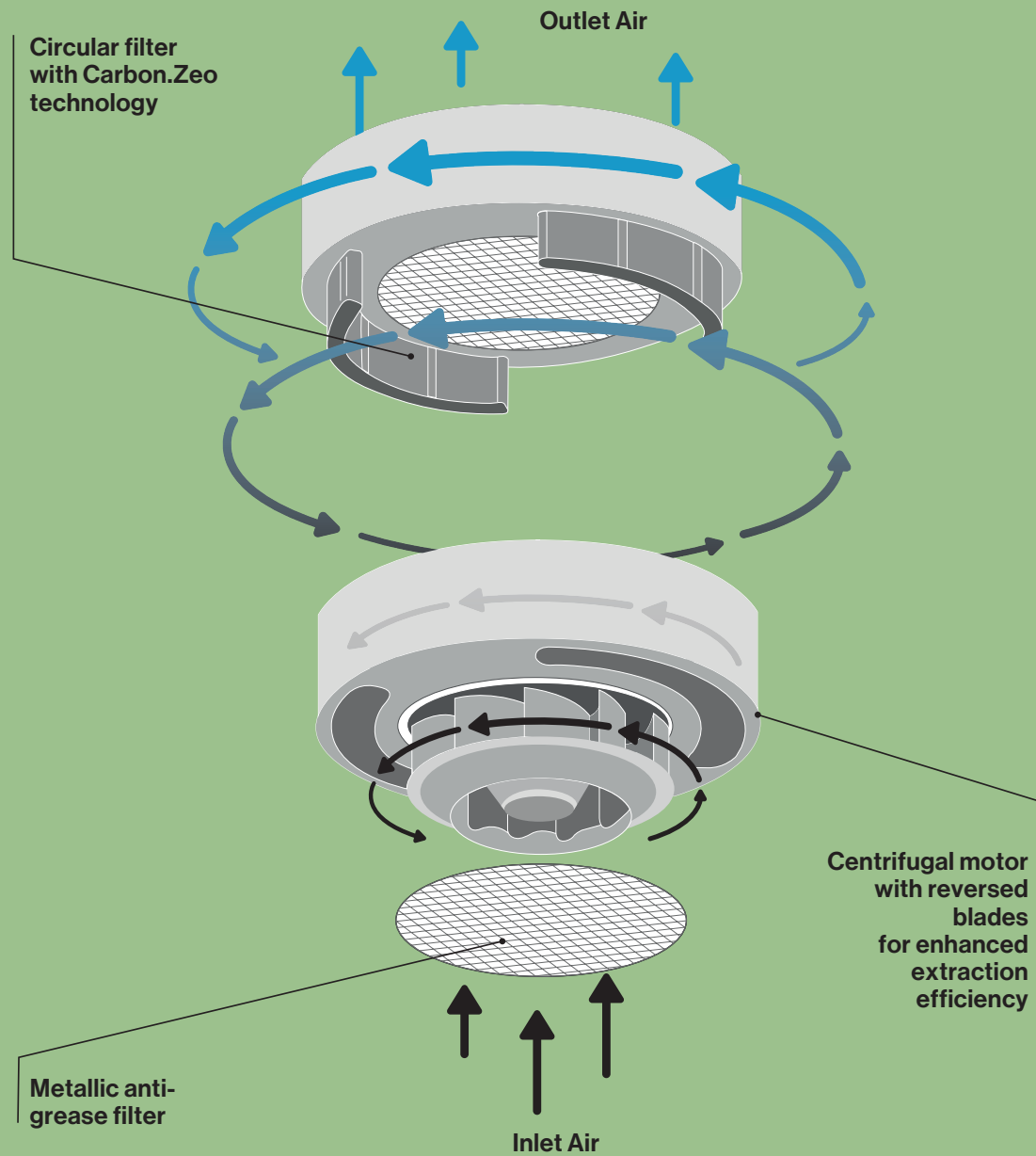

Carbon.

Active carbons are materials made principally of carbon in the form of graphite microcrystals, specially treated to create a porous structure with a vast internal surface area. These characteristics make it capable of trapping the molecules of many different types of substance, attracting and absorbing them.

Zeolite.

Zeolite is a mineral with a high capacity for absorbing organic compounds and water vapour. This property is directly due to the microporous nature of its crystalline structure. In addition, the chemical characteristics of zeolite mean that it releases heat on contact with moisture, thus reducing it. The use of zeolite is therefore important both for reducing odours and for absorbing water vapour produced during cooking.

Long-lasting product, simple maintenance.

The Carbon.Zeo combined filter has a long life, lasting at least 3 years, and up to 5 years, under normal conditions of use. We recommend to regenerate the filter every 18 months by placing it in an oven at 200°C for two hours. This process is extremely easy, with extraction performed in the lower part of the hood.

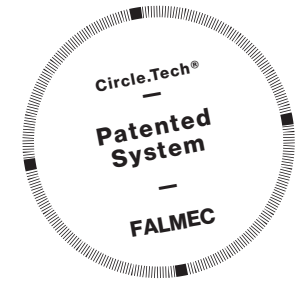

Learn more about our Circle.Tech technology.



Spazio NEW

- Stainless or black-painted steel chassis
- Circle.Tech technology with Carbon.Zeo filters
- Smoked glass shelves
- LED lighting
- Removable and washable metallic grease filter
- Equipped with power outlets and USB ports
- Ladle hanger, spices shelf, tablet holder included
- Indoor plants growing area (optional Falmec accessory)
- Remote control included
- Dialogue System-ready.

Spare parts

Filter: Carbon.Zeo
KACL.944

Optional accessories

Tissue holder (Black)
KACL.746#HF

Tissue holder (Steel)
KACL.746#IF

Kit 2 trays
KACL.744#IF

Light for plants growing area
KACL.745#IF

Extension Rods Kit Steel
KACL.748#IF

Extension Rods Kit Black
KACL.748#HF

Island – 180 cm

Motor and Control
600 m³/h
3 spd + boost, electronic control
Anti-odour filters
Carbon.Zeo
Lighting
4 x strip Led
(3000 K)
Sound pressure level
Min. speed
48dB(A)re1pW
Max. speed
61dB(A)re1pW
Minimum distance from cooker top
Gas hob: 65 cm
Electric hob: 52 cm
Weight
68 kg

Island – 180 cm
Black – 600 m³/h
8034122476964

Island – 180 cm
Steel – 600 m³/h
8034122476957

Design Francesco Lucchese

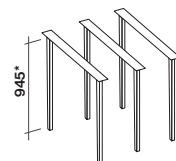
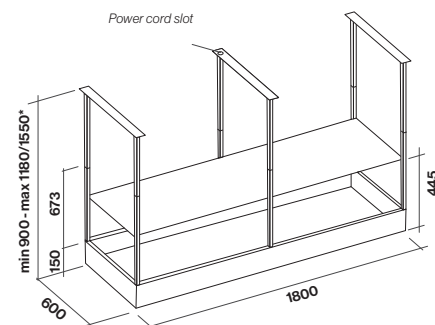

*Max height with rod extension: 1550 mm.

Matte black / Steel



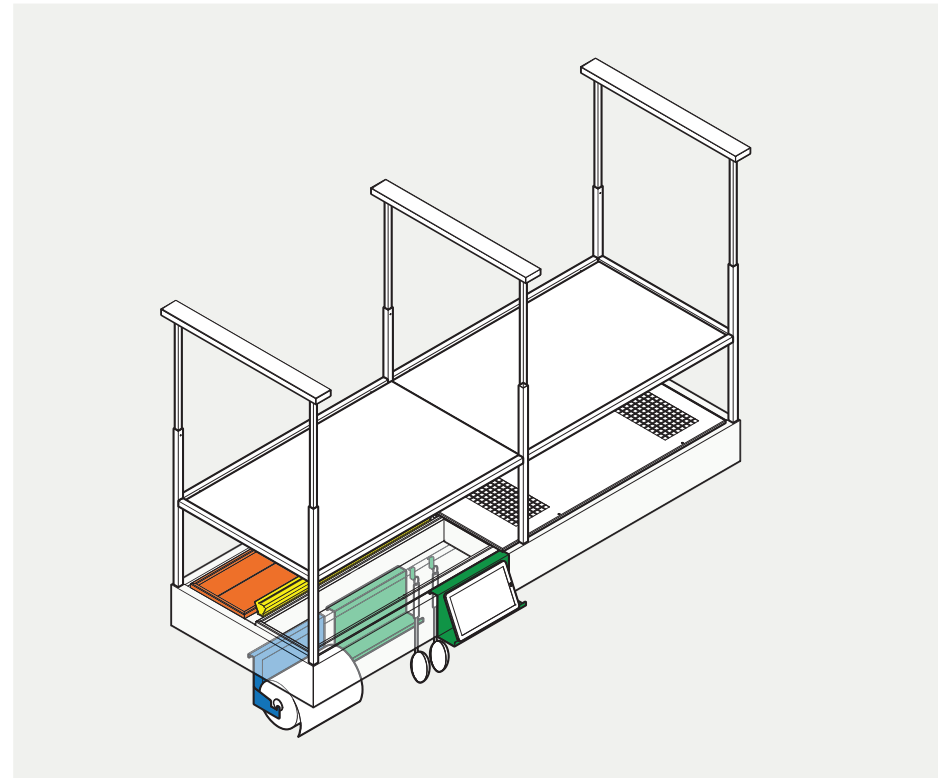

Included accessories

- Tablet holder
- Spices holder
- Ladle holder hooks

Optional accessories

- KACL.746#HF
Tissue holder (Black)
- KACL.746#IF
Tissue holder (Steel)

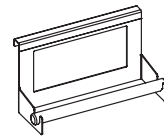

- KACL.744#IF
Kit 2 trays for plants growing area

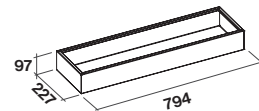

- KACL.745#IF
Light for plants growing area

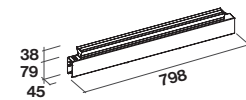

Design
Francesco Lucchese

Spazio is a system that amplifies the features of a suspended hood. Its versatility is a keypoint that we reached by increasing available room around the hood, allowing use on multiple levels, for a complete and dynamic experience. On the hanging support shelf the plants are a living presence for a real interaction with the "ingredients" necessary for good cooking. The activities on the work surface are facilitated by a hanging rail for all the accessories and by a large lighting surface. The choice to create an air support has increased the capacity of the worktop, with a suspended kitchen area that multiplies its usability both on the horizontal and on the vertical plane, fully adapting to the work in the kitchen.



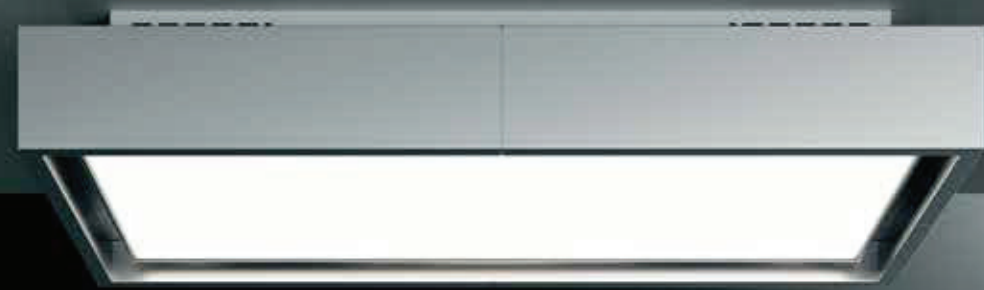

Circle.Tech
Vega



Vega **NEW**

- AISI 304 Stainless steel, painted white or black
- Tempered glass
- Circle.Tech technology with Carbon.Zeo filters
- Perimeter suction
- All-surface Led lighting
- Removable and washable metallic filter
- Remote control included
- Dialogue System-ready.

Spare parts

Filter: Carbon.Zeo
KACL.944

Ceiling – 115 cm

Motor and Control

600 m³/h
3 spd + boost, electronic control
Anti-odour filters
Carbon.Zeo filter

Lighting

Dynamic Led Light
50 W (2700-5600 K)

Sound pressure level

Min. speed
48dB(A)re1pW

Max. speed
61dB(A)re1pW

Minimum distance from cooker top

150 cm

Weight
45 kg

Ceiling – 115 cm

White – 600 m³/h
8034122477169

Ceiling – 115 cm

Black – 600 m³/h
8034122477176

Ceiling – 115 cm

Steel – 600 m³/h
8034122476940

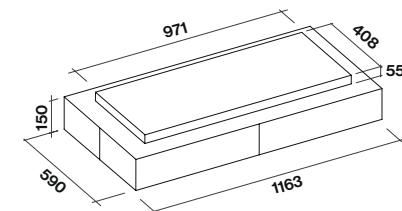

Design
Emo Design

Vega is a filtering ceiling hood defined by a meticulous care of proportions, that with the use of Falmec Circle.Tech technology, allowed to design a product with extremely simple and light looks. The thin frame, available in different finishes, is separated into symmetrical segments that delineate a vertical visual detail making the product harmonious and delicate. Finally, the perimeter suction and the lower lighting panel define an architectural and rational product suitable for all kitchen environments.

White / Black / Steel



Life inspired.



Levante NEW

- Up/Down lift system with height adjustment
- AISI 304 Stainless steel
- Stainless Steel Frame
- Tempered glass
- Circle.Tech technology with Carbon.Zeo filters
- Perimeter extraction
- Removable and washable metallic filter
- All-surface Dynamic Led lighting
- Remote control included
- Dialogue System-ready.

Spare parts

Filter: Carbon.Zeo
KACL.944

Island (Up/Down) – 120 cm

Motor and Control

600 m³/h
3 spd + boost, electronic control

Anti-odour filters

Carbon.Zeo filter

Lighting

Dynamic Led Light
50 W (2700-5600 K)

Sound pressure level

Min. speed
48dB(A)re1pW

Max. speed
61dB(A)re1pW

Minimum distance

from cooker top

Gas hob: 57 cm

Electric hob: 52 cm

Weight

71 kg

Island (Up/Down) – 120 cm

White – 600 m³/h
8034122477183

Island (Up/Down) – 120 cm

Black – 600 m³/h
8034122476933

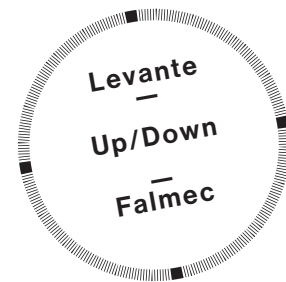
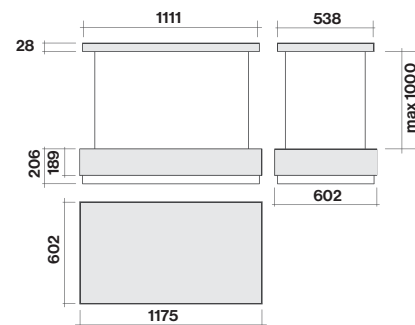

White / Black

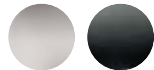

Circle.Tech
Levante



Life inspired.

Sophie **NEW**

- Painted/polished steel
- Circle.Tech technology with Carbon.Zeo filters
- Rotary switch
- Perimeter suction with glass panel
- Led lighting
- Removable and washable metallic filter
- Optional remote control
- Dialogue System-ready.

Spare parts

Filter: Carbon.Zeo
KACL.944

Optional accessories

Cables: adjustable up to 340 cm
KACL.143

Remote control
105080053

Island – 54 cm

Motor and Control
600 m³/h
3 spd + boost, rotary switch

Anti-odour filters
Carbon.Zeo filter

Lighting
Led stripe
18 W (4200 K)

Sound pressure level

Min. speed
47dB(A)re1pW

Max. speed
60dB(A)re1pW

Minimum distance from cooker top
Gas hob: 53 cm
Electric hob: 52 cm

Weight
21 kg

Island – 54 cm

White – 600 m³/h
8034122358031

Island – 54 cm

Anthracite – 600 m³/h
8034122358048

Island – 54 cm

Pewter – 600 m³/h
8034122476773

Island – 54 cm

Worn Copper – 600 m³/h
8034122476872

Island – 54 cm

Worn Brass – 600 m³/h
8034122476759

Emo Design

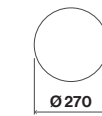
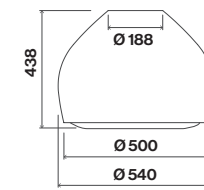

Island support, adjustable cables range
44-110 cm

White / Anthracite / Pewter / Worn Copper / Worn Brass



Circle.Tech
Sophie



Life inspired.

Circle.Tech
Dama





Circle.Tech
Dama

Dama **NEW**

- Painted steel or copper
- Circle.Tech technology with Carbon.Zeo filters
- Rotary switch
- Perimeter suction with glass panel
- Led lighting
- Ambient led lighting
- Removable and washable metallic filter
- Optional remote control
- Dialogue System-ready.

Spare parts

Filter: Carbon.Zeo
KACL.944

Optional accessories

Cables: adjustable up to 340 cm
KACL.143

Remote control
105080053

Island - 60 cm

Motor and Control
600 m³/h
3 spd + boost, rotary switch

Anti-odour filters
Carbon.Zeo filter

Lighting
Led 4x1,2 W (4200 K)
Ambient
14 W (4200 K)

Sound pressure level
Min. speed
48dB(A)re1pW
Max. speed
61dB(A)re1pW

Minimum distance from cooker top
Gas hob: 56 cm
Electric hob: 52 cm

Weight
21 kg

Island - 60 cm
White - 600 m³/h
8034122357997

Island - 60 cm
Gunmetal - 600 m³/h
8034122476704

Island - 60 cm
Steel - 600 m³/h
8034122476889

Island - 60 cm
Copper - 600 m³/h
8034122476728

Emo Design

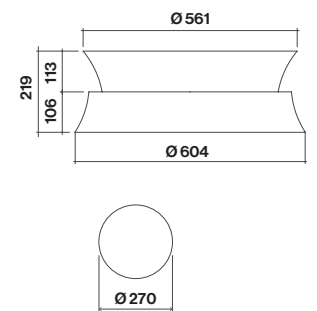

Island support, adjustable cables range 44-110 cm

White / Gunmetal / Stainless Steel / Copper



Life inspired.



Materia **NEW**

- Single-shell concrete body
- Circle.Tech technology with Carbon.Zeo filters
- Electronic control
- Led lighting
- Removable and washable metallic filter
- Remote control included
- Dialogue System-ready.

Spare parts

Filter: Carbon.Zeo
KACL.944

Optional accessories

Cables: adjustable up to 340 cm
KACL.144

The crafting of this hood makes this product unique, since there cannot be two identical pieces. Small blemishes are not to be considered as defects, but a confirmation of this special process.

Concrete



Island – 100 cm

Motor and Control

600 m³/h
3 spd + boost, electronic control

Anti-odour filters

Carbon.Zeo filter

Lighting

Led 4x1,2 W (3200 K)

Sound pressure level

Min. speed

48dB(A)re1pW

Max. speed

61dB(A)re1pW

Minimum distance from cooker top

Gas hob: 61 cm

Electric hob: 52 cm

Weight

30 kg

Island – 100 cm

Concrete – 600 m³/h
8034122476841

Design Saggia-Sommella

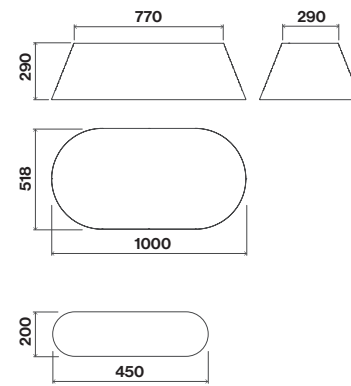

Island support, adjustable cables range
44-110 cm



As awarded by
The Chicago
Athenaeum:
Museum of
Architecture
and Design.

Circle.Tech
Materia





Circle.Tech
Vetra

Vetra **NEW**

- Scotch Brite stainless steel (AISI 304) or white finishing
- Tempered glass
- Circle.Tech technology with Carbon.Zeo filters
- Electronic control
- Perimeter led lighting
- Removable and washable metallic filter
- Optional remote control for wall version, included for island version.

Spare parts

Filter: Carbon.Zeo
101078810

Optional accessories

Cables: adjustable up to 340 cm
KACL.144
(Island version)

Remote control
105080053

Island – 120 cm
Wall – 90 cm

Motor and Control
600 m³/h
3 spd + boost, electronic control
Anti-odour filters
Carbon.Zeo filter

Lighting
Led stripe
Island 120 cm
84 W (5500 K)
Wall 90 cm
40 W (5500 K)

Sound pressure level
Min. speed
48dB(A)re1pW
Max. speed
61dB(A)re1pW
Minimum distance from cooker top
Gas hob: 57 cm
Electric hob: 52 cm
Weight
Wall version: 25 kg
Island version: 41 kg

Wall – 90 cm
White – 600 m³/h
8034122476810

Wall – 90 cm
Steel – 600 m³/h
8034122476827

Island – 120 cm
White – 600 m³/h
8034122476780

Island – 120 cm
Steel – 600 m³/h
8034122476797

Design Saggia-Sommella

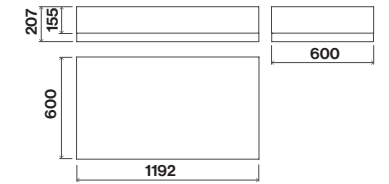

Island version

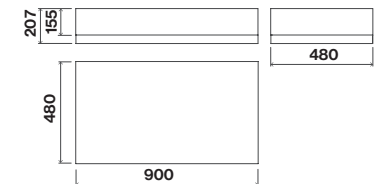

Wall version

Steel / White





Circle.Tech
Soffio



Soffio NEW

- Handmade blown glass
- Circle.Tech technology with Carbon.Zeo filters
- Rotary switch
- Perimeter suction with glass panel
- Led lighting
- Led ambient light
- Removable and washable metallic filter
- Optional remote control
- Dialogue System-ready.

Spare parts

Filter: Carbon.Zeo
KACL.944

Optional accessories

Cables: adjustable up to 340 cm
KACL.143

Remote control
105080053

The crafting of this hood makes this product unique, since there cannot be two identical pieces. Small blemishes are not to be considered as defects, but a confirmation of this special process.

Island – 58 cm

Motor and Control
600 m³/h
3 spd + boost, rotary switch
Anti-odour filters
Carbon.Zeo filter

Lighting
Led 4x1,2 W (4200 K)
Ambient
15 W (4200 K)

Sound pressure level
Min. speed
48dB(A)re1pW

Max. speed
61dB(A)re1pW

Minimum distance from cooker top

Gas hob: 56 cm
Electric hob: 52 cm

Weight
21 kg

Island – 58 cm
White – 600 m³/h
8034122476735

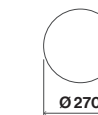
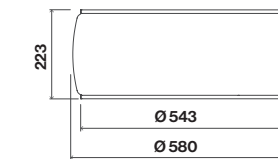

Island support, adjustable cables range 44-110 cm



White Satin Glass



Life inspired.



Loop **NEW**

- Painted steel
- Circle.Tech technology with Carbon.Zeo filters
- Rotary switch
- Perimeter suction with glass panel
- Led lighting
- Led ambient light
- Removable and washable metallic filter
- Optional remote control
- Dialogue System-ready.

Spare parts

Filter: Carbon.Zeo
KACL.944

Optional accessories

Cables: adjustable up to 340 cm
KACL.143

Remote control
105080053

Island – 74 cm

Motor and Control
600 m³/h
3 spd + boost, rotary switch

Anti-odour filters
Carbon.Zeo filter

Lighting
Led 4x1,2W (4200 K)
Ambient

8W (4200 K)
Sound pressure level

Min. speed
48dB(A)re1pW

Max. speed
61dB(A)re1pW

Minimum distance from cooker top

Gas hob: 56 cm
Electric hob: 52 cm

Weight
29 kg

Island – 74 cm

White – 600 m³/h
8034122358017

Island – 74 cm
Gunmetal – 600 m³/h
8034122476858

Island – 74 cm
Steel – 600 m³/h
8034122476896

Emo Design

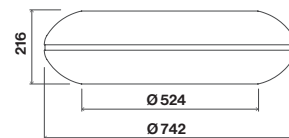

Island support, adjustable cables range
44-110 cm

White / Gunmetal / Steel



Circle.Tech
Loop

